





DESCRIPTION

The terpTRAP terpene recovery module from extraktLAB is the most versatile cold trap available for terpene and vapor recovery in pre-extraction decarboxylation processes. The heat exchanger is capable of 20 tons of heat exchange capacity and process connections to support chilling, vacuum, and condensates produced by the largest decarboxylation processes. Food grade contact surfaces allow for recovery of terpenes for use in downstream formulations prior to coming in contact with ethanol or other extraction solvents.

FEATURES

-  **Versatile Design to Protect Vacuum Pumps**
-  **Full Spectrum Terpene Recovery**
-  **GMP Compliant Product Contact Surfaces**
-  **Scalable up to 10 tons/day (depending on Biomass Moisture Content)**
-  **Maximize the Throughput of Any Decarboxylation System**



EXTENDED

PROCESSING POWER

- 4 Gallon Standard Collection Pot
- 21.64 sq ft of Heat Exchange Area
- 1hp Standard Chiller Size
- 0 to 27.8 "Hg Relative Vacuum Rating

PROCESS CONTROL

- Decarboxylation Vapor Recovery
- Vacuum Pump Cold Trap
- Decreasing Moisture Carryover to Ethanol
- Compatible with High CFM & Low-Pressure Vacuum Pumps

GMP COMPLIANCE

- Metals: 316 Stainless Steel
- Polymers: Viton, Buna-N
- FDA Approved Materials
- International Certifications

SPECIFICATIONS

ATTRIBUTE	VALUE
General Specifications	
Dimensions (in)	L52 × W47 x H89
Unit Weight (lbs)	130
Sound Pressure (db)	<60
Footprint (sq ft)	25
Process Connection Length, KF 40 bellows (ft)	40
Certifications	UL 508A
Condenser	
Number of Condensers	1
Condenser Exchange Area (sq ft)	21.6
Required Vacuum ("Hg)	27
Collection Vessel/Expeller	
Collection Volume (gal)	4
Material	316 SS
Vacuum Pump (Standard)	
Dimensions (in)	L17 × W7.5 x H12
Unit Weight (lbs)	24.5
Voltage (V)	120
Pump FLA	3
Intake Exhaust Thread NPT (in)	0.25
Free Air Displacement (l/min)	7.1
Ultimate Vacuum Pressure (torr)	60
Maximum Vacuum ("Hg)	27.6

ATTRIBUTE	VALUE
External Chiller (Standard)	
Chiller Footprint (in)	L27.6 × W14.5 x H22.6
Chiller Voltage (V)	230
Phase	1
Frequency (Hz)	60
Chiller FLA (A)	10
Cooling Range (°C)	- 10 to 40
Cooling Capacity @ 10°C	1925 w (60HZ)
Chiller Fluid (Glycol/Water)	30/70
Chiller Fluid Reservoir (liters)	4.2
Chiller Fluid Max Flow Rate (l/min)	13.2
Chiller Fluid Max Pressure (psi)	100
Temperature Stability (°)	+/- 0.1
Refrigerant	R134A
Product Contact Materials	
Metals	316 SS
Polymers	Viton Buna-N
Installation, Training, and Warranty	
Installation & Training Included (days)	2
Quality and Labor	Parts & Workmanship
Duration (years)	3

LINE DRAWINGS

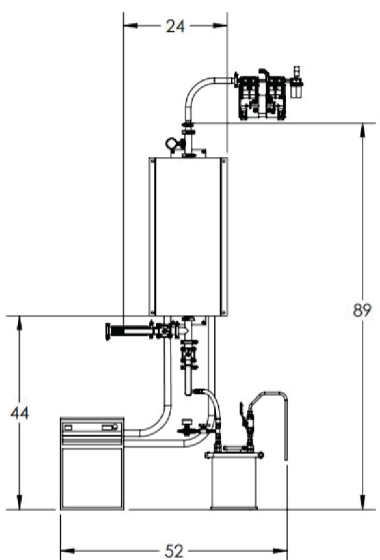

SIDE VIEW

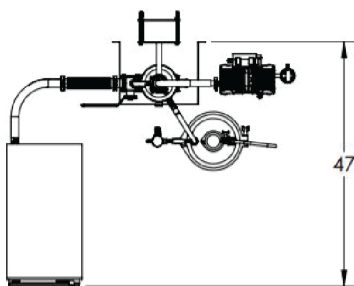

TOP VIEW

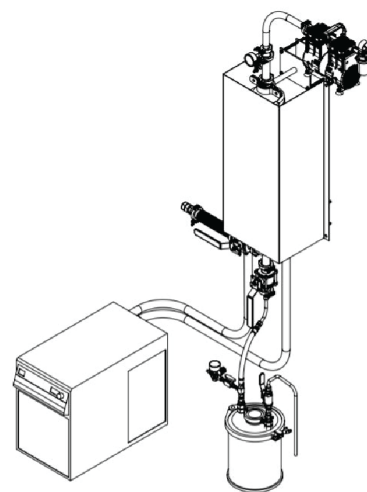

FRONT VIEW

terpTRAP

651-600-0036 | EXTRAHLAB.COM
811 PINE ST. SAINT CROIX FALLS, WI 54024



UNITED SCIENCE
www.unitedscience.com